

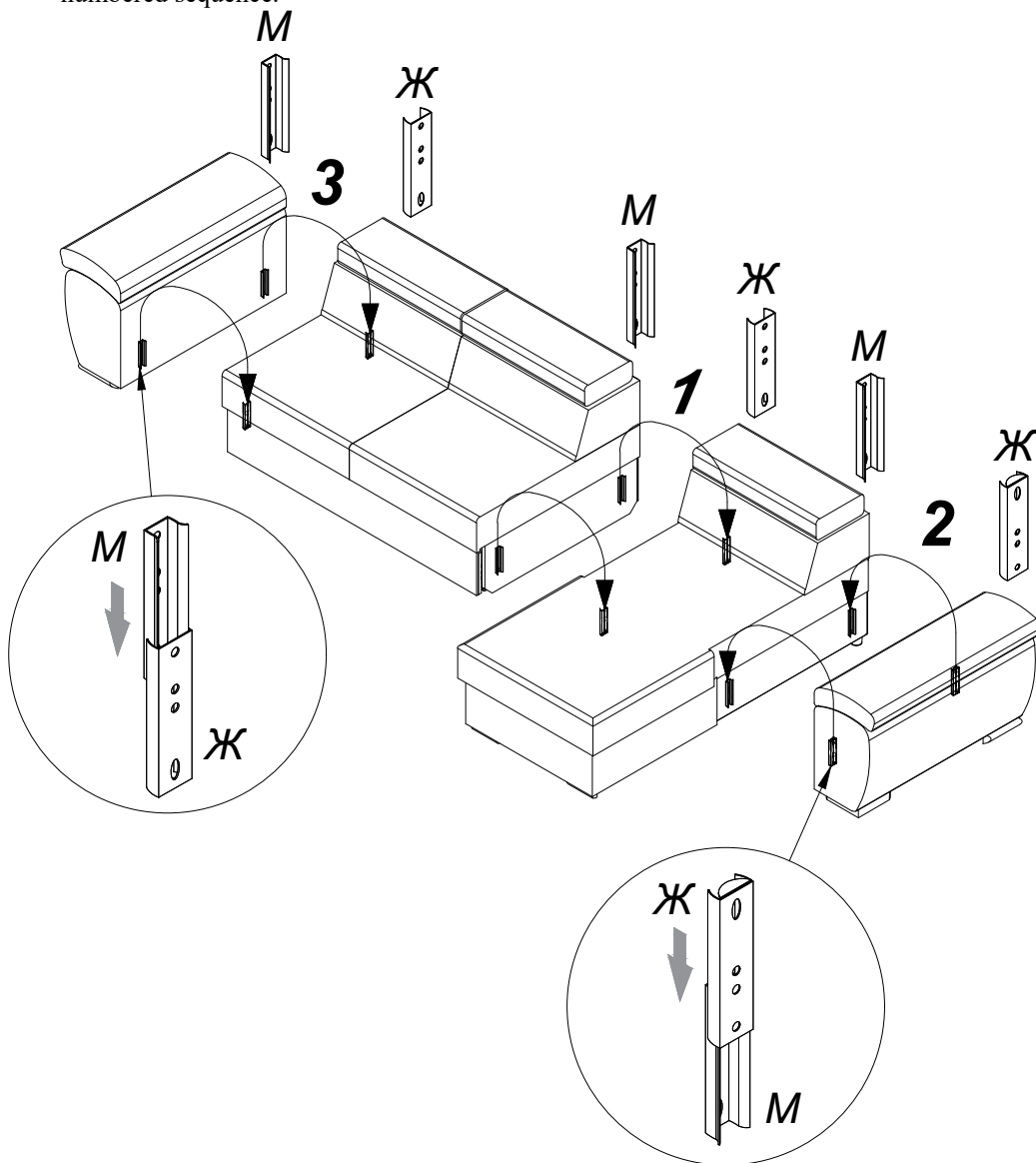

3. Connectez les quatre modules aux charnières intégrées. S'il vous plaît, suivez la séquence numérotée.

3. За да закачите четирите модула, се използват вградените планки. Моля, следвайте посочената с цифри последователност.

3. To connect the four modules the integrated hinges are used. Please, follow the numbered sequence.



## Монтажна схема Installation manual Notice de montage

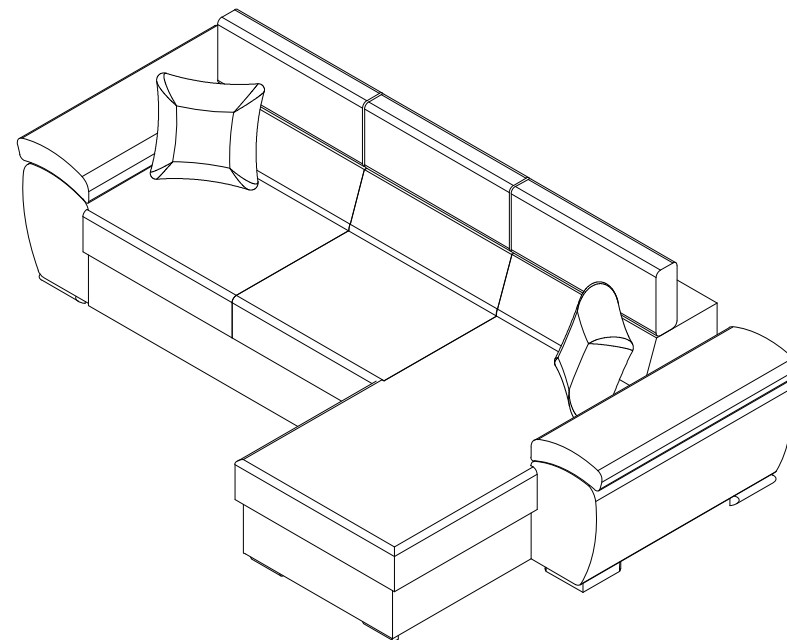

<p>Крак - 4 бр. Pieds - 4 pcs. Legs - 4 pcs.</p>	<p><b>A</b> Крак - 2 бр. Pieds - 2 pcs. Legs - 2 pcs.</p>	<p><b>B</b> Крак - 2 бр. Pieds - 2 pcs. Legs - 2 pcs.</p>	<p><b>C</b> Винт - 6x35 - 22 бр. Vis - 6x35 - 22 pcs. Screw - 6x35 - 22 pcs.</p>	<p><b>D</b></p>
<p>Колело - 2 бр. Roue - 2 pcs. Wheel - 2 pcs.</p>	<p><b>E</b> Гайка - M6 - 4 бр. Écrou M6 - 4 pcs. Nut M6 - 4 pcs.</p>	<p><b>F</b></p>		



Attention! The installation of the legs, can be done by one person.

For the installation of the feet you will need only a screwdriver.



Внимание! Монтирането на краката, може да се извърши от един човек.

За монтажа на краката ще ви е нужна само отвертка.



Attention! L'installation des pieds peut être effectuée par une seule personne.

Pour l'installation des pieds, un tournevis est nécessaire



1. Montage des roulettes sur la fonction lit.

1. Монтиране на колелата върху функцията на леглото.

1. Mounting the wheels on the bed function.

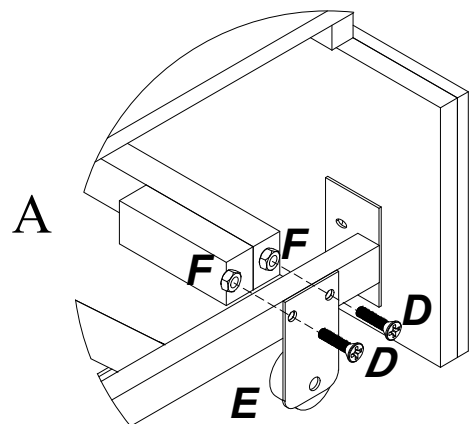
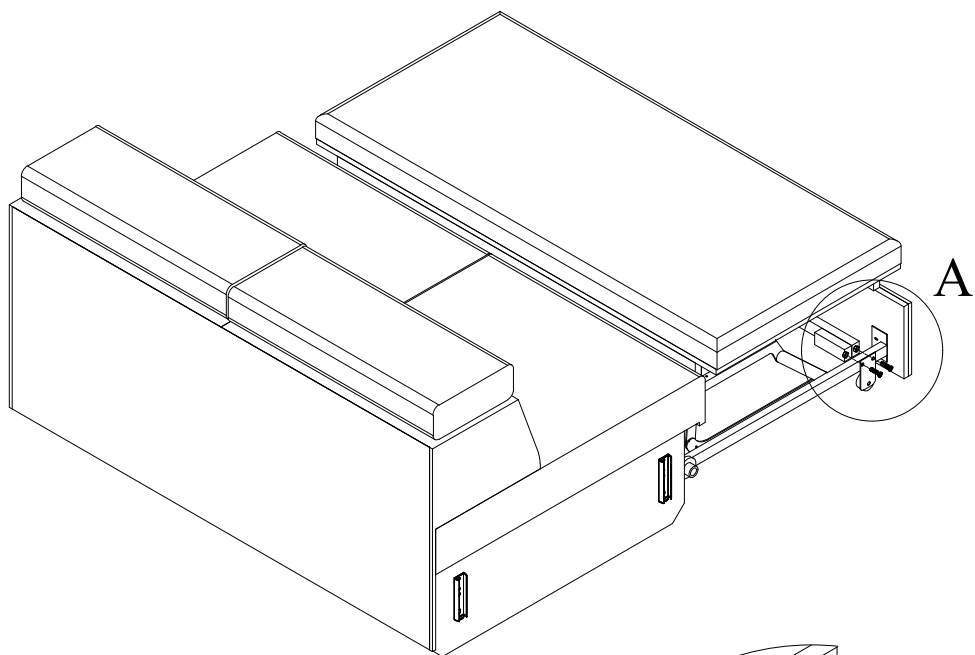

2. Montage des pieds.

2. Монтиране на краката.

2. Mounting of the legs.

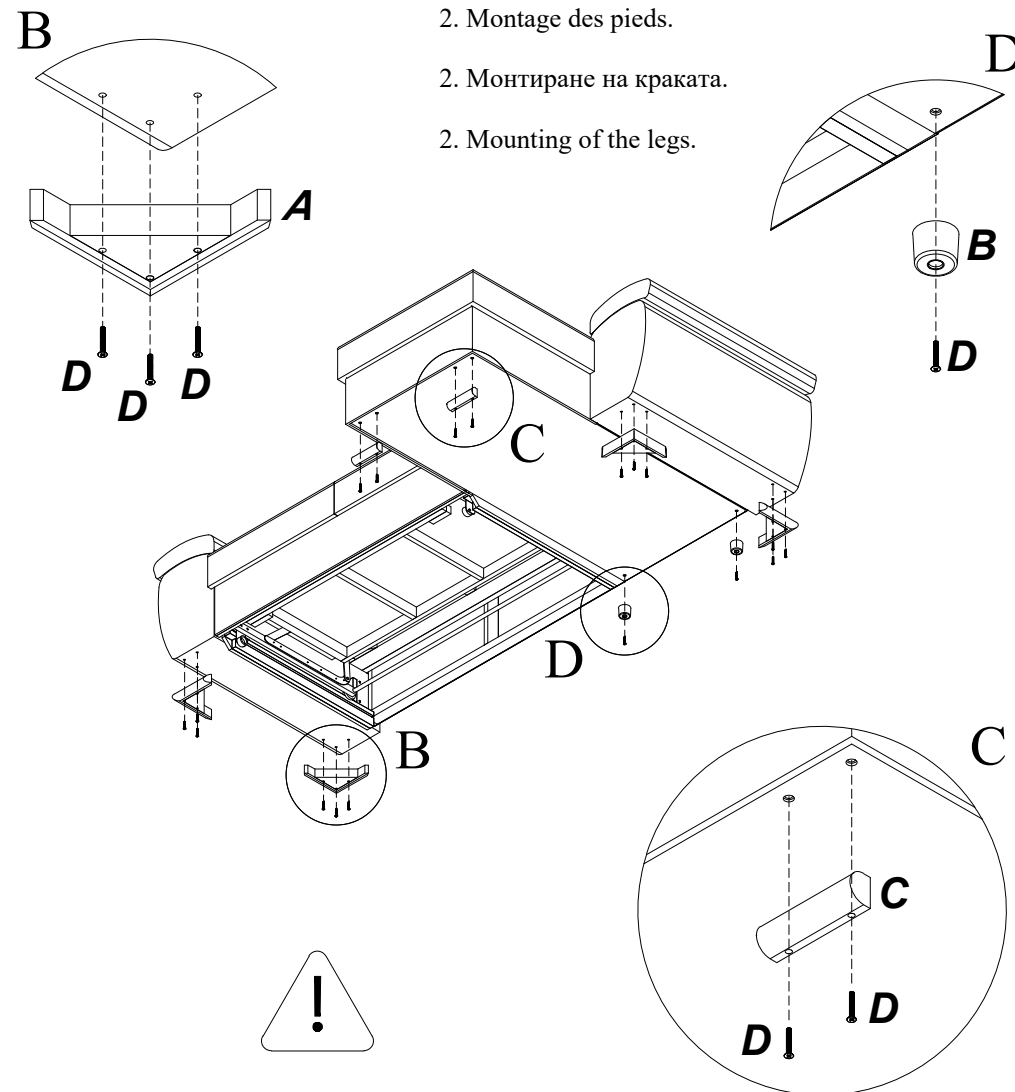

Les lieux des pieds sont marqués d'un trou, où les jambes doivent être placés.

Мястото за монтаж на краката е маркирано с отвор.

The legs assembly is marked with a hole.